

STEP 1. MAKING A SAMPLE DOOR

- A) This sample door size is 12" wide by 20" long.
- B) The door thickness should be 3/4" - 7/8"

STEP 2. DETERMINING THE SIZES OF EACH PART OF THE DOOR

- A) Always use a 1/2" overlay on all sides of the door.
 - B) If the door opening is 11" wide by 19" high then the door size is 12" x 20".
- IMPORTANT: Use 2-1/2" wide stiles so the templates will work properly.

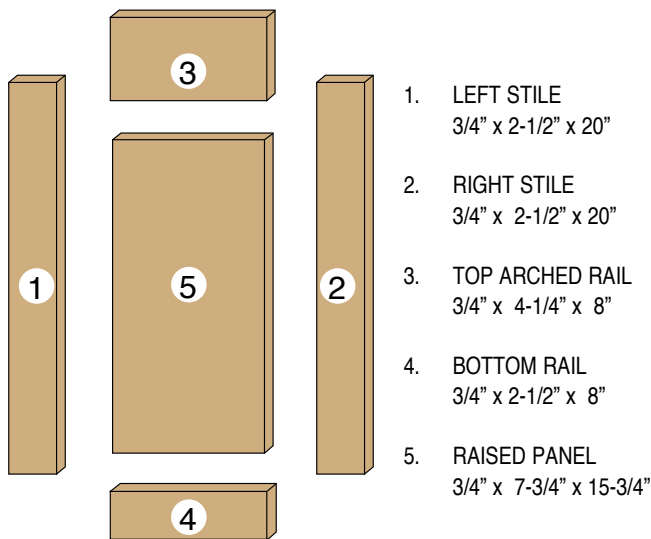

1-2. LEFT AND RIGHT STILES

- a) Always cut stiles 2-1/2" wide.
- b) Length of stiles is same as door length.

3. TOP ARCHED RAIL

- a) Cut 4-1/4" wide. Templates are 4" wide (cut 5-1/4" wide for French Provincial doors).
- b) Length of rail is found by subtracting 4" from the total door width. (Overall door width is 12" minus 4" = 8" length of rail) NOTE: This following procedure can only be used when using 2-1/2" wide stiles. Subtract 4" from the total door width instead of 5" since 1/2" in each stile will be taken up in the pattern cut.

4. BOTTOM RAIL

- a) Always cut 2-1/2" wide.
- b) Length of rail is again found by subtracting 4" from the total door width. (Overall door width is 12" minus 4" = 8" for bottom rail lengths)

5. RAISED PANEL

- a) Width is always 1/4" less than rail length. (1/8" space should be left on each side for expansion of panel)
- b) Rail length is 8" minus 1/4" = 7-3/4" width of raised panel.
- c) Length of raised panel is found by taking the overall door length and again subtracting 4". (Overall door length is 20" minus 4" = 16", or 15-3/4" with panalign strips)

At this time all 5 pieces of the door should be cut to the correct size.

STEP 3. CUTTING THE COPE CUTS ON EACH END OF THE 2 RAILS

- A) Cope cutter is the cutter with the bearing in the middle
- B) Set the cope cutter to the correct height in the router.
 - 1) The correct height is when, after the cut is made, the reveal on the front side should be 1/8" minimum (Illustration 1)
 - 2) Spaces A and B shown should be equal. If one is to be bigger, make B thicker for strength of panel.

C) Set fence even with bearing.

D) Use wooden push-block to prevent tearout at end of cope cut.

E) Run stock through with good side down at 14,000-16,000 RPMs.

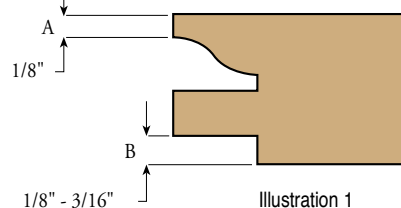

STEP 4. USING RAIL TEMPLATE TO FLUSH TRIM TOP RAIL TO CORRECT SHAPE

- A) Locate center of top rail with pencil on the back side.
- B) Pick out the correct template.

NOTE: THE SIZE ON THE TEMPLATE IS FOR THE OVERALL DOOR WIDTH. FOR THE TEMPLATES TO WORK PROPERLY STILES MUST BE MADE 2-1/2" WIDE. IF STILES ARE MADE IN DIFFERENT WIDTHS, ADJUSTMENTS IN PICKING OUT TEMPLATES MUST BE MADE.
- C) Line up template on back side of rail centering the notch of template with center line of rail. Now nail through the template into the 2 copes that were just cut (Illustration 2).

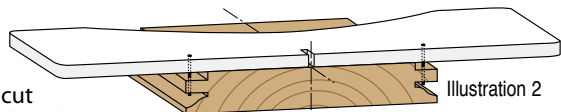

D) Rough cut with jig or band saw within 1/8" or 1/4" of template (Illustration 3).

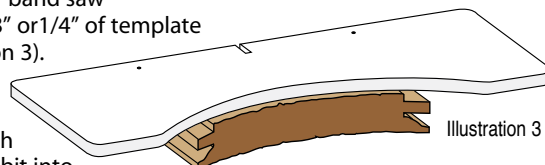

E) Put flush trimming bit into router and set so bearing is flush with template (Illustration 4).

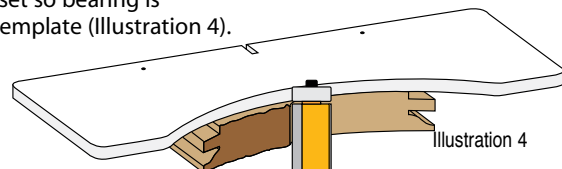

F) Run router at 20,000-22,000 RPMs and flush trim top crown rail with good side down.

NOTE: WHEN STARTING CUT, ALWAYS REMEMBER TO MAKE CONTACT WITH BEARING TO A PLACE ON THE TEMPLATE WHERE THERE IS NO WOOD TO PREVENT KICKBACK.

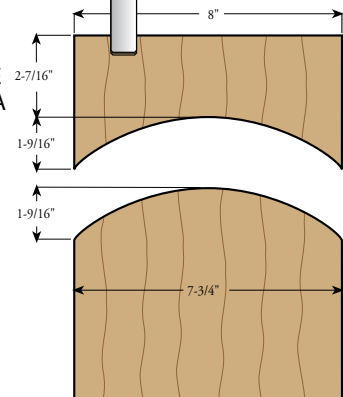

G) Slow down at end of cut to prevent tearout. Leave template attached to rail for now