

STEP 5. USING PANEL TEMPLATE TO FLUSH TRIM THE RAISED PANEL TO SHAPE

- A) Locate center of raised panel on front side.
- B) Pick out correct template (same size as rail template).
- C) Line up center notch of template with center line of panel and make sure it is also square (Illustration 5).
- D) Nail template to panel about 1/2" in from each side (Illustration 5).

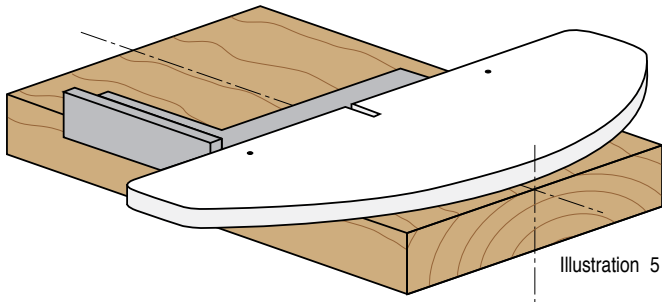

Illustration 5

NOTE: DRIVE NAILS IN ABOUT 1/4"-3/8". THE NAIL HOLES WILL BE MACHINED OUT WHEN RAISED PANEL CUT IS MADE.

- E) Rough cut stock to within 1/8" - 1/4" of template.
- F) Flush trim raised panel in the same manner as you did the top rail with the template on top (Back to illustration 4).
- NOTE: AGAIN MAKE SURE BEARING COMES IN CONTACT WITH TEMPLATE FIRST AND THEN GUIDE INTO THE WOOD.
- G) Pull nails out after flush trimmed.

STEP 6. CUTTING FREEHAND PATTERN CUT ON TOP ARCHED RAIL

- A) Pattern cutter is the cutter with the bearing on top.
- B) Insert pattern cutting bit to correct height to match cope cut. This can be done by making a few practice cuts in scrap wood.
- C) Run router at 14,000-16,000 RPMs.
- D) Start cut with bearing making contact with template only and ease into cut. No fence is used. (Illustration 6).
- E) Slow down at end of cut to prevent any chipout.
- F) Remove template from top arched rail.

STEP 7. CUTTING THE STRAIGHT BOTTOM RAIL AND 2 STILES

- A) Insert fence and line up fence with bearing on the same pattern cutter.
- B) Run router 14,000-16,000 RPMs
- C) Use push block and push bottom rail through with good side down.

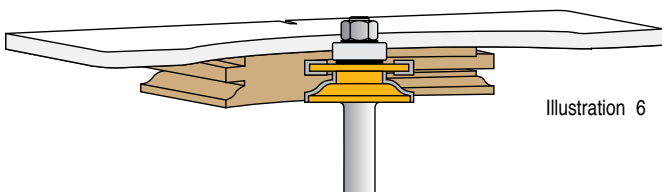

Illustration 6

STEP 8. MAKING RAISED PANEL CUT

- A) Insert panel cutter to correct height.
NOTE: IT MAY TAKE A COUPLE OF PRACTICE CUTS IN SCRAP WOOD BEFORE GETTING THE PANEL FLUSH WITH PATTERN CUT.
- B) Set fence so it is even with bearing on panel cutter.
- C) Run router slow 10,000 RPMs. ALWAYS USE PUSH BLOCKS FOR SAFETY.
- D) Make first cut across the grain with good side face down.
- E) Cut with the grain on left side.
- F) Remove fence and use a half-fence. (Illustration 7)
- G) Start by re-doing left side and come around and cut the curved top of the panel freehand.
- H) Install full fence and complete right side.

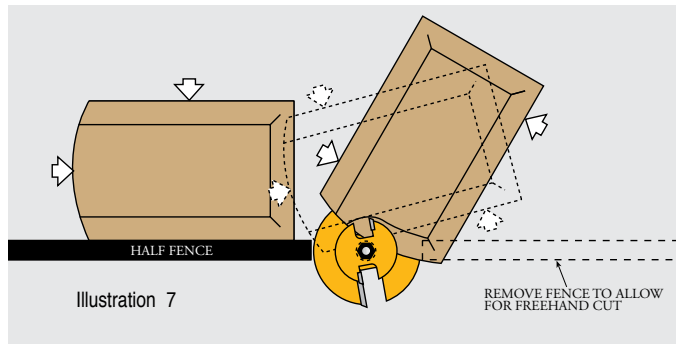

Illustration 7

REMOVE FENCE TO ALLOW FOR FREEHAND CUT

STEP 9. FINISHING

- A) Sand all pieces where needed, insert Panalign Strips (see catalog page 29), and glue up. Do not glue raised panel itself, only cope cuts and where they meet the pattern cuts.
- B) After the door is sanded, use the door edger bit for a professional-looking edge treatment. (Illustration 8)
- C) For a mini-raised panel cut on the drawers, use the drawer front bit. (Illustration 9)

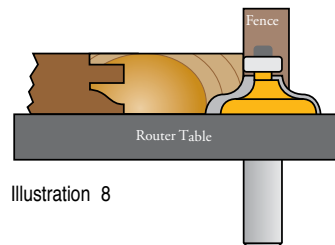

Illustration 8

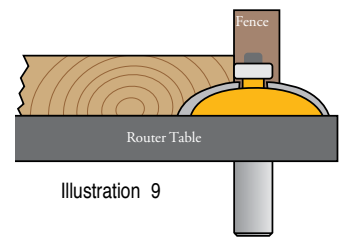

Illustration 9

For more help order our video "Arched Raised Panels Made Easy," showing everything here in much greater detail.

Buy this DVD with the Sommerfeld Cabinetmaking Set (page 18) or Raised Panel Set (page 19) and Save \$5.00!

DVD: DVD1
SALE: \$4.90

